

the Bambino™ Plus

SES500



EN QUICK GUIDE

Sage®

- 2 Sage® recommends safety first
- 6 Know your new appliance
- 8 Operating your new appliance
- 14 Care & cleaning
- 17 Troubleshooting

SAGE® RECOMMENDS SAFETY FIRST

At Sage® we are very safety conscious. We design and manufacture appliances with your safety foremost in mind. We also ask that you exercise a degree of care when using any electrical appliance and adhere to the following precautions.

IMPORTANT SAFEGUARDS

FOR ALL ELECTRICAL APPLIANCES

- The full information book is available at sageappliances.com
- Before using the first time ensure your electricity supply is the same as shown on the label on the underside of the appliance.
- Remove and safely discard any packaging materials before first use.
- To eliminate a choking hazard for young children, safely discard the protective cover fitted to the power plug.
- This appliance is for household use only. Do not use the appliance for anything other than its intended use. Do not use in moving vehicles or boats. Do not use outdoors. Misuse may cause injury.
- Fully unwind the power cord before operating.
- Position the appliance on a stable, heat resistant, level, dry surface away from the edge and do not operate on or near a heat source such as a hot plate, oven or gas hob.
- Do not let the power cord hang over the edge of a bench or table, touch hot surfaces or become knotted.
- Do not leave the appliance unattended when in use.
- To protect against electric shock do not immerse the power plug, cord or appliance in water or any liquid.

WE RECOMMEND SAFETY FIRST

- Always ensure the appliance is turned OFF, unplugged at the power outlet and has been allowed to cool before cleaning, attempting to move or storing.
- Always turn the appliance to the off position, switch off at the power outlet and unplug at the power outlet when the appliance is not in use.
- Regularly inspect the supply cord, plug and actual appliance for any damage. If found damaged in any way, immediately cease use of the appliance and return the entire appliance to the nearest authorised Sage Service Centre for examination, replacement or repair.
- Keep the appliance and accessories clean. Follow the cleaning instructions provided in this book. Any procedure not listed in this instruction booklet should be performed at an authorised Sage® Service Centre.
- Children should not play with the appliance.
- Cleaning of the appliance should not be carried out by children unless they are 8 years or older and supervised.
- The appliance and its cord should be kept out of reach of children aged 8 years and younger.
- The installation of a residual current safety switch is recommended to provide additional safety when using all electrical appliances. Safety switches with a rated operating current not more than 30mA are recommended. Consult an electrician for professional advice.
- Do not use attachments other than those provided with the appliances.
- Do not attempt to operate the appliance by any method other than those described in this booklet.
- Do not move the appliance whilst in operation.
- Do not touch hot surfaces. Allow the appliance to cool down before moving or cleaning any parts.
- The appliance can be used by children aged 8 or older and persons with reduced physical, sensory or mental capabilities or a lack of experience and knowledge, only if they have been given supervision or

WE RECOMMEND SAFETY FIRST

instruction concerning use of the appliance in a safe way and understand the hazards involved.

- Use only tap water in the water tank. Do not use any other liquid.
- Never use the appliance without water in the water tank.
- Ensure the portafilter is firmly inserted and secured into the brewing head before using the machine.
- Never remove the portafilter during the brewing operation as the machine is under pressure.
- Do not place anything, other than cups for warming, on top of the appliance.
- Heating element surface is subject to residual heat after use.

SPECIFIC INSTRUCTIONS FOR SES500

- This appliance is recommended for household use only. Do not use this appliance for other than its intended use. Do not use in moving vehicles or boats.

Do not use outdoors. Misuse may cause injury.

- If the appliance is to be:
 - left unattended
 - cleaned
 - moved
 - assembled; or
 - storedalways switch Off the espresso machine by simultaneously pressing the 1 CUP and STEAM buttons. Switch off at the power outlet and unplug.
- Ensure the product is properly assembled before first use.
- Do not use the Bambino™ Plus inside a cabinet.
- Do not use any other liquid apart from cold mains/ tap water. We do not recommend the use of highly filtered, de-mineralised or distilled water as this may affect the taste of the coffee and how the espresso machine is designed to function.
- Ensure the portafilter is firmly inserted and secured into the group head before starting the extraction. Never remove the portafilter during the brewing process.

WE RECOMMEND SAFETY FIRST

- Do not leave the product unattended when in use.
- Do not touch hot surfaces. Allow the product to cool down before moving or cleaning any parts.
- Use caution when operating the machine, as metal surfaces are liable to get hot during use.
- Use caution when descaling as hot steam may be released. Before descaling, ensure drip tray is inserted. Refer to 'Care & Cleaning' for further instructions.
- Protect cartridges from heat and direct sunlight.
- Do not use damaged filter cartridges.
- Do not open filter cartridges.
- If you are absent for a prolonged period of time, empty the water tank and replace the cartridge.



The symbol shown indicates that this appliance should not be disposed of in normal household waste.

It should be taken to a local authority waste collection centre designated for this purpose or to a dealer providing this service. For more information, please contact your local council office.



To protect against electric shock, do not immerse the power cord, power plug or appliance in water or any other liquid.



WARNING

Do not immerse power cord, power plug or appliance in water or any other liquid.



WARNING

Misuse may cause injury.

SPECIFIC INSTRUCTIONS FOR WATER FILTER

- Filter cartridge should be kept out of reach of children.
- Stores filter cartridges in a dry place in the original packaging.

SAVE THESE INSTRUCTIONS

KNOW YOUR NEW APPLIANCE

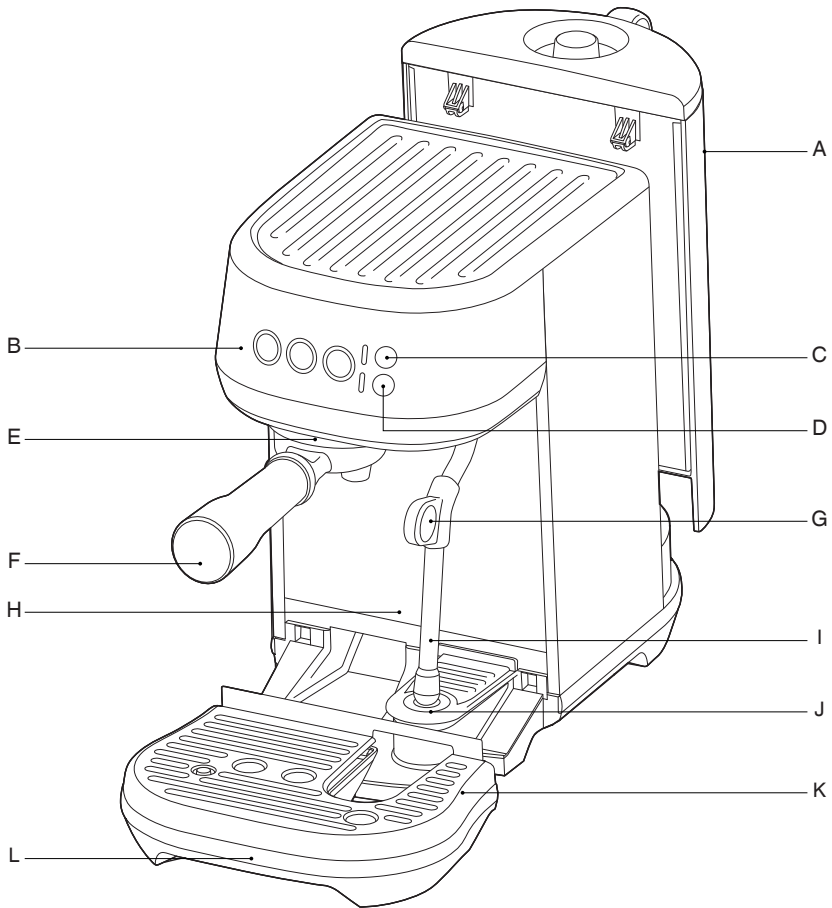

- A. 1.9L removable water tank
- B. Control panel
1 CUP, 2 CUP and STEAM buttons
With preset shot durations or programmable durations and volumes
- C. MILK TEMP settings
Select from Warm, Ideal and Hot
- D. MILK FOAM settings
Select from Low, Medium and High
- E. Group head
- F. 54mm stainless steel portafilter

- G. Steam wand grip
- H. Extra-tall cup clearance for tall mugs
- I. Steam wand
With automatic milk texturing
- J. Milk jug temperature sensor
- K. Removable drip tray grid
- L. Removable drip tray
With full indicator

KNOW YOUR NEW APPLIANCE

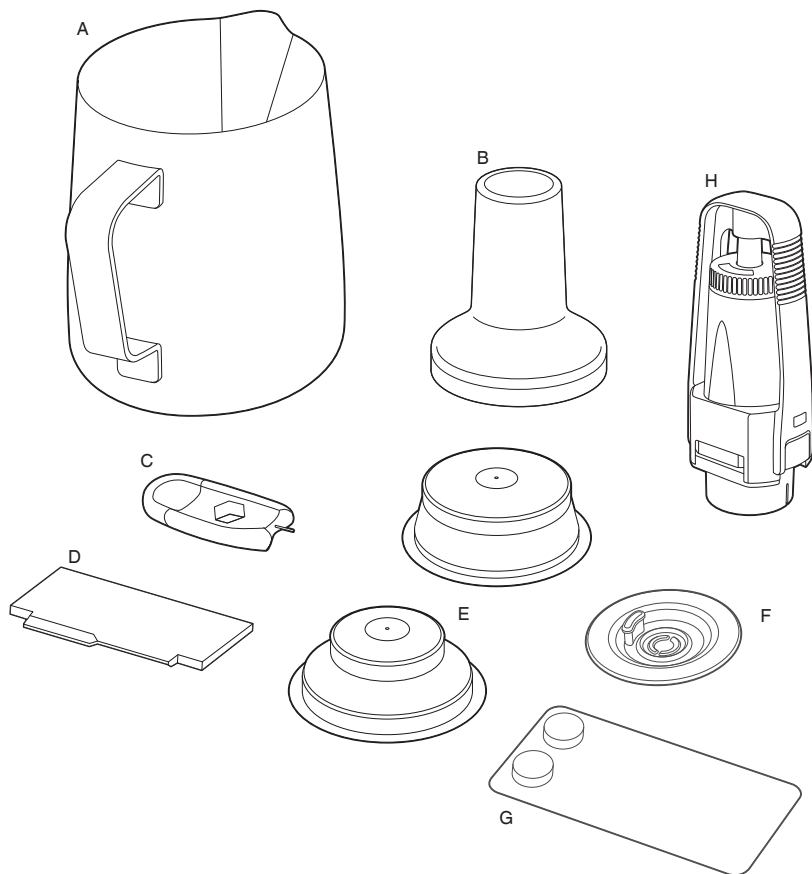

ACCESSORIES

- A. Stainless steel milk jug
With MIN and MAX markings
- B. 54mm tamper
- C. Steam tip cleaning tool
- D. The Razor™ precision trimming tool
- E. Dual wall filter baskets (1 cup & 2 cup)
- F. Cleaning disc
- G. Espresso cleaning tablets
- H. Water filter holder with filter

CE Rating Information
220-240V ~50-60Hz 1300-1600W

OPERATING YOUR NEW APPLIANCE

BEFORE FIRST USE

Machine Preparation

Remove and discard all labels and packaging materials attached to your machine. Ensure you have removed all parts and accessories before discarding the packaging.

Clean the drip tray, drip tray grid, portafilter, filter baskets and milk jugs using warm water and a gentle dish washing liquid. Rinse well and dry thoroughly before use.



INSTALLING THE WATER FILTER

1. Remove the water filter and water filter holder from the packaging.
2. Set the reminder for the next month of replacement. We recommend to replace the filter after 3 months.

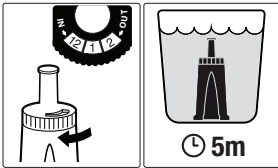

3. Soak the filter in cold water for 5 minutes.
4. Wash the filter holder with cold water.

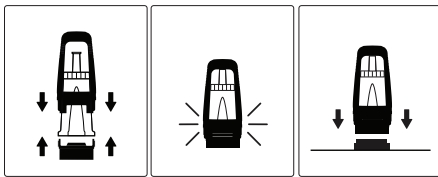

5. Insert the filter into the two parts of the filter holder. Ensure they are connected.
6. Remove the water tank from the machine. Align the base of the filter holder with the adapter inside the water tank. Push down to lock into place.

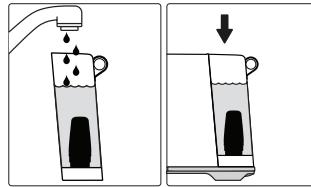

7. Fill the water tank with cold potable water and reattached the machine, ensuring it is properly attached and sitting flush to the back of the machine.

FIRST USE

1. Remove the water tank and fill with potable water to the indicated MAX line. Replace the water tank onto the machine.
2. Ensure that the drip tray is correctly positioned on the machine.
3. Plug the power cord into the power outlet and switch on.
4. Press the 1 CUP, 2 CUP or STEAM buttons to turn the machine on.

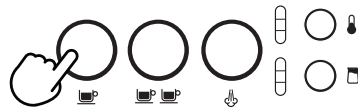

5. Press the 1 CUP button and the machine will commence its first use cycle.
6. Once complete, the machine will go into ready mode and all lights will be illuminated. The first use cycle is to rinse the machine and prime the heating system.

TURNING OFF MACHINE

To turn the machine off, press the 1 CUP and STEAM button simultaneously.

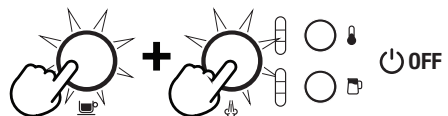

OPERATING YOUR NEW APPLIANCE



FILLING THE WATER TANK

Lift the water tank from the machine. Remove the water tank lid and add potable water to the water tank, filling to the MAX marking indicated.

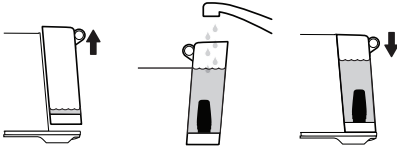

Replace the water tank onto the machine, ensuring it is properly attached and sitting flush against the back of the machine.

If the 1 CUP, 2 CUP and STEAM buttons illuminate, the water tank has been correctly attached.

The machine will detect when the water level is low. The 1 CUP, 2 CUP and STEAM buttons will not be illuminated.

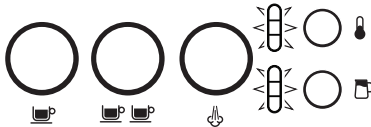

When this occurs, add water to the water tank. Once there is sufficient water, all buttons will be illuminated and the machine can be used.

FILTER BASKETS

This machine includes dual wall 1 Cup and 2 Cup filter baskets.

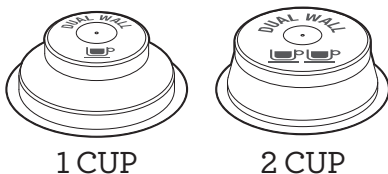

Use the 1 cup filter basket when brewing a single cup and the 2 cup filter baskets when brewing 2 cups or a stronger single cup or mug.

The provided filter baskets are designed for:

1 Cup filter basket = 8-10g.

2 Cup filter basket = 16-19g

COFFEE DOSE AND TAMPING

- Insert the filter basket into the portafilter.
- Grind enough coffee to fill the filter basket.
- Tap the portafilter several times to collapse and distribute the coffee evenly in the filter basket.
- Using the tamper, tamp down firmly (approx. 15-20kgs of pressure). The amount of pressure is not as important as the consistent pressure every time.

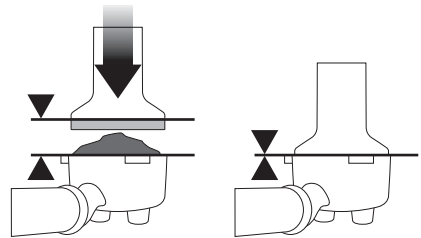

- As a guide, the top edge of the cap on the tamper should be level with the top of the filter basket AFTER the coffee has been tamped.

NOTE

Use Razor™ dose trimming tool to precisely control the dose of ground coffee AFTER you tamp.

TRIMMING THE DOSE

The Razor™ precision dose trimming tool allows you to trim the puck to the right level for a consistent extraction.

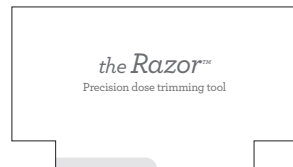

- Insert the Razor™ tool into the coffee basket until the shoulders of the tool rest on the rim of the basket.
- Rotate the Razor™ dosing tool back and forth while holding the portafilter on an angle over the knock box to trim off excess coffee grounds. Your coffee filter is now dosed with the correct amount of coffee.

OPERATING YOUR NEW APPLIANCE

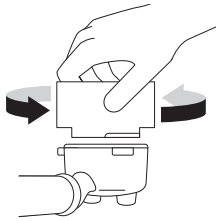

- Wipe excess coffee from the rim of the filter basket to ensure a proper seal is achieved in the group head.

PURGING THE GROUP HEAD

Before placing the portafilter into the group head, run a short flow of water through the group head by pressing the 1 CUP button. This will stabilise the temperature prior to extraction.

INSERTING THE PORTAFILTER

Place the portafilter underneath the group head so that the handle is aligned with the INSERT position. Insert the portafilter into the group head and rotate the handle towards the centre until resistance is felt.

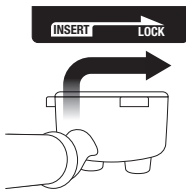

Place your cup/s under the portafilter on the drip tray.

PRE-PROGRAMMED SHOT VOLUME

- 1 CUP

Press the 1 CUP button once, the button will flash indicating that it has been selected. A preset single espresso volume of approximately 30mls will be extracted. The machine will automatically stop once the pre-set volume has been extracted.

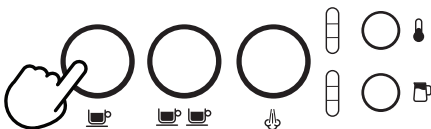

PRE-PROGRAMMED SHOT VOLUME

- 2 CUP

Press the 2 CUP button once, the button will flash indicating that it has been selected. A preset single espresso volume of approximately 60mls will be extracted. The machine will automatically stop once the pre-set volume has been extracted.

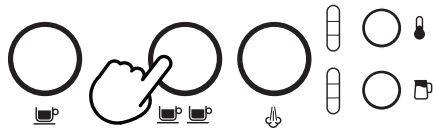

NOTE

Pressing the 1 CUP or 2 CUP buttons during a programmed espresso will immediately stop the extraction.

MANUAL PRE-INFUSION AND SHOT VOLUME

Press and hold the 1 CUP or 2 CUP button for the desired pre-infusion time. Release the button to start the extraction. Press the flashing button again to stop the extraction.

PROGRAMMING SHOT VOLUME

Press and hold the 1 CUP and 2 CUP buttons for 2 seconds, the buttons will illuminate and flash.



To set the 1 CUP volume:

- Press the 1 CUP button to start the extraction.
- Press the 1 CUP button again to stop the extraction. The modified volume will be saved.

To set the 2 CUP volume, follow the above steps but select the 2 CUP button to start and stop the extraction.

OPERATING YOUR NEW APPLIANCE

SETTING THE MILK TEMPERATURE

The machine has 3 milk temperature settings;

- 1 Warm
- 2 Ideal
- 3 Hot



When turning on the espresso machine, the milk temperature setting will default to the last chosen setting. Press the MILK TEMP button until the desired temperature is illuminated.

SETTING THE MILK FOAM

The machine has 3 milk foam settings;

- 1 Low
- 2 Medium
- 3 High



When turning on the machine, the milk foam setting will default to the last chosen setting. Press the MILK FOAM button until the desired foam setting is illuminated.

NOTE

Prior to texturing milk, it is recommended to momentarily purge the steam wand. To do this press the STEAM button to start purging and press it again to stop.

- Start with fresh cold milk.
- Fill the milk jug to between the min and max position.
- Lift the steam wand and insert into the milk jug.
- Lower the steam wand, ensuring it is fully down.
- The milk jug must rest on the milk temperature sensor located on the drip tray and the milk should cover the steam wand tip.

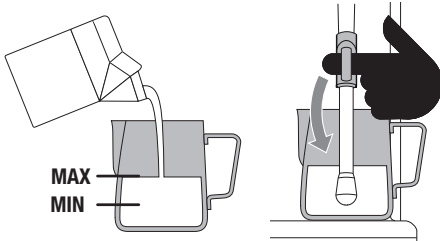

Milk should cover this part

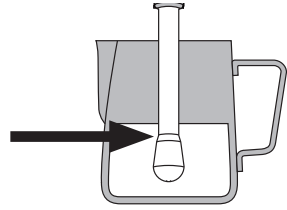

- Press the MILK TEMP and MILK FOAM buttons to select the desired settings.
- Press the STEAM button, the button will flash while texturing.
- The milk texturing will stop automatically when the selected milk temperature is reached.
- Lift the steam wand to remove the milk jug.
- Wipe the wand and tip with a clean damp cloth.
- Lower the steam wand to the down position and the steam wand will automatically purge.

NOTE

Pressurised steam can still be released, even after the machine has been switched off. Children must always be supervised.

NOTE

When the machine creates steam, a pumping noise can be heard. This is normal operation.

NOTE

Use only the supplied stainless steel milk jug to froth milk using this machine. The use of other containers may lead to dangerous conditions.

OPERATING YOUR NEW APPLIANCE

MANUAL MILK TEXTURING

- Auto milk texturing and auto shut-off are disabled during manual milk texturing.
- Fill the milk jug to between the MIN and MAX markings.
- Lift the steam wand and insert into the milk jug with the steam wand tip 1-2cm below the surface of the milk, close to the right-hand side of the jug at a 3 o'clock position.
- Press the STEAM button to begin texturing.



- Keep the steam wand tip just under the surface of the milk until the milk is spinning clockwise, producing a vortex (whirlpool effect).
- With the milk spinning, slowly lower the jug. This will bring the steam wand tip to the surface of the milk and start to introduce air into the milk.
- Gently break the surface of the milk with the tip to get the milk spinning fast enough.
- Keep the steam wand tip at or slightly below the surface, continuing to maintain the vortex. Texture the milk until sufficient volume is obtained.
- Lift the jug to lower the tip beneath the surface but keep the vortex spinning. The milk is at the correct temperature (60-65°C) when the jug is hot to touch.



- When texturing is complete, press the STEAM button.
- Remove the steam wand from the milk jug.
- Wipe the wand and tip with a clean damp cloth.
- Lower the steam wand to the down position and the steam wand will automatically purge.

STEAM WAND PURGING

After texturing milk, the steam wand must be returned to the lowered position and allowed to automatically purge. Not doing so, could result in the steam wand blocking.

If the steam wand remains in the raised position, the machine will display a lower steam wand alert; illuminating the MILK TEMP and MILK FOAM lights in a downwards pattern, identifying that the steam wand needs to be lowered.





To manually commence the steam wand purge, with the steam wand lowered, press and hold the STEAM button for 5 seconds.

OPERATING YOUR NEW APPLIANCE

EXTRACTION TIPS

A great espresso is about achieving the perfect balance between sweetness, acidity, and bitterness. The flavour of your coffee will depend on many factors, such as the type of coffee beans, degree of roast freshness, coarseness or fineness of the grind, dose of ground coffee and tamping pressure.

Experiment by adjusting these factors just one at a time to achieve the taste of your preference.

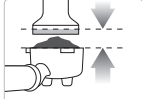
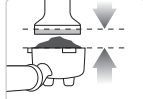
CORRECT EXTRACTION	UNDER EXTRACTION	OVER EXTRACTION
		
<ul style="list-style-type: none"> • Flow starts after 8-12 secs • Flow slow like warm honey • Crema is golden brown with a fine mousse texture • Espresso is dark brown 	<ul style="list-style-type: none"> • Flow starts after 1-7 secs • Flow fast like water • Crema is thin and pale • Espresso is pale brown • Tastes bitter/sharp, weak and watery 	<ul style="list-style-type: none"> • Flow starts after 13 secs • Flow drips or not at all • Crema is dark and spotty • Espresso is very dark brown • Tastes bitter and burnt
<p>AFTER EXTRACTION</p>	<p>SOLUTIONS</p>	<p>SOLUTIONS</p>
<p>REMOVE USED GRINDS</p> <p>Used grinds will form a coffee 'puck'. If the puck is wet, refer to the 'Under Extraction' section.</p> 	<p>EXPERIMENT WITH GRIND:</p> <ul style="list-style-type: none"> • Grind needs to be finer for a slower extraction. • Ensure you are controlling dose with the Razor™. 	<p>EXPERIMENT WITH GRIND:</p> <ul style="list-style-type: none"> • Grind needs to be coarser for a faster extraction. • Ensure you are controlling dose with the Razor™.
<p>RINSE FILTER BASKET</p> <p>Keep the filter basket clean to prevent blockages. Without ground coffee in the filter basket, lock the portafilter into the machine and run hot water through.</p> 	<p>ALWAYS TAMP TO LINE</p> <p>Adjust & re-test</p>  <p>Tamp using 15-20kgs of pressure. The top edge of metal cap on the tamper should be level with the top of the filter basket AFTER tamping.</p> <p>Trim the puck to the right level using the Razor™ precision dose trimming tool.</p>	<p>ALWAYS TAMP TO LINE</p> <p>Adjust & re-test</p>  <p>Tamp using 15-20kgs of pressure. The top edge of metal cap on the tamper should be level with the top of the filter basket AFTER tamping.</p> <p>Trim the puck to the right level using the Razor™ precision dose trimming tool.</p>

CARE & CLEANING



REPLACING THE WATER FILTER

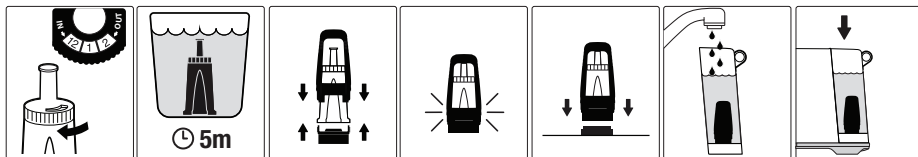

The provided water filter helps prevent scale build-up in and on many of the inner functioning components. Replacing the water filter after 3 months or 40L will reduce the need to descale the machine.

+ + CLEANING CYCLE

The machine will detect when 200 extractions have been carried out since the last cleaning cycle; this will be shown by the 1 CUP and 2 CUP buttons alternately flashing.

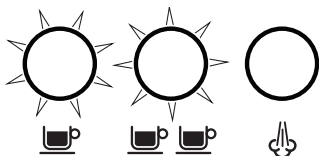

To bypass the cleaning cycle; press the STEAM button. The machine will go back to ready mode, but will display cleaning alert again the next time that the machine is turned on.

1. Insert the provided cleaning disc into the filter basket in the portafilter.
2. Place a cleaning tablet on top of the cleaning disc.
3. Lock the portafilter into the group head.
4. Empty the drip tray and replace onto the machine. Place a 2L / 68 fl.oz container under the portafilter and steam wand sitting on the drip tray.

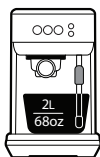

5. Fill the water tank to the MAX line then reattached to the machine, ensuring it is correctly attached.
6. Press and hold the 1 CUP and 2 CUP buttons for 5 seconds to enter the cleaning cycle mode.



7. The 1 CUP and 2 CUP buttons will remain illuminated. Press either 1 CUP or 2 CUP to begin the cleaning cycle. When the cycle is in progress, the lights will alternately flash.
8. Once the cycle is complete the machine will ready to ready mode.
9. Remove and rinse the portafilter, cleaning disc, drip tray and container.

🌐 DESCALING

After regular use, hard water can cause mineral build up in and on many of the inner functioning components, reducing the brewing flow, brewing temperature, power of the machine, and the taste of the espresso.

The machine will indicate that it requires descaling when the 1 CUP and STEAM button and the 2 CUP button flash alternately for 15 seconds. Pressing any of these buttons will cancel the alert and return the machine to ready mode.

CARE & CLEANING

WARNING

Do not immerse the power cord, power plug or appliance in water or any other liquid. The water tank should never be removed or completely emptied during descaling.

TO DESCAL

1. Empty the drip tray and re-insert into position on the machine.
2. Fill the water tank to the **DESCALE** line indicated and add the descaling agent to the water.

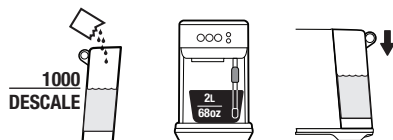

3. Place a 2L / 68 fl.oz container under the grouphead and steam wand.
4. Turn the machine off by simultaneously pressing the 1 CUP and STEAM buttons, and allow it to completely cool before descaling.



5. With the machine off, press the 1 CUP and STEAM buttons simultaneously for 5 seconds to enter descale mode.

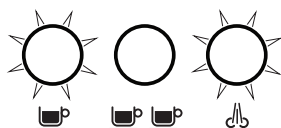

6. The 1 CUP and STEAM buttons will illuminate, indicating that the machine is ready to start descaling.



7. Press the 1 CUP or STEAM button to begin the descale cycle. These buttons will alternately flash throughout the cycle.
8. Once the descale solution has been used up, the descale mode will pause. Refill the water tank to the MAX line and empty the waste water container, then replace both parts on to the machine.
9. The 1 CUP and STEAM buttons will illuminate when the machine is ready. Press the 1 CUP or STEAM button to resume descaling.
10. When descaling is complete, the 1CUP and STEAM button will alternately flash. The machine will then go into standby mode.

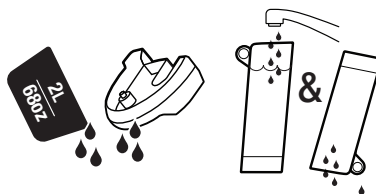

11. Remove and empty the waste water container. Rinse the drip tray and water tank and dry thoroughly before replacing them back onto the machine.

STEAM WAND BLOCKED

During milk texturing, if the machine detects that the steam wand is blocked, it will immediately stop operating and the STEAM button light will be off. Both the milk temperature and milk foam lights will fully illuminate and flash. These lights will flash until a manual steam purge has been completed.



CLEANING THE STEAM WAND

- The steam wand should always be cleaned after texturing milk. Wipe the steam wand with a damp cloth.

CARE & CLEANING

- If any of the holes in the tip of the steam wand become blocked, it may reduce frothing performance. Manually purge the steam wand to try and clear the holes.
- If the steam wand remains blocked, unscrew the steam wand tip and use the cleaning tool to unblock the holes; cleaning tool is located in the back of the machine, under the water tank.

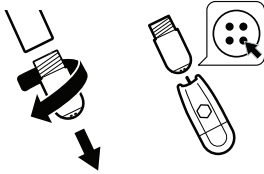

- Rinse the steam tip and wipe with a clean, dry cloth. Reassemble the steam wand by screwing the steam tip back on to the steam wand. Purge the steam wand after cleaning.

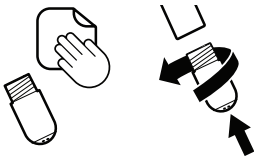

CLEANING THE FILTER BASKETS AND PORTAFILTER

- The filter baskets and portafilter should be rinsed under hot water directly after use to remove all residual coffee oils.
- If the holes in the filter baskets become blocked, use the steam wand cleaning tool to unblock the holes.

CLEANING THE SHOWER SCREEN

- The group head interior and shower screen should be wiped with a damp cloth to remove any ground coffee particles.
- Periodically run hot water through the machine with the filter basket and portafilter in place, without any ground coffee, to rinse out any residual coffee.

CLEANING THE DRIP TRAY

- The drip tray should be removed, emptied and cleaned after each use or when the drip tray indicator rises through the drip tray grid.
- Remove the drip tray grid and wash both parts in warm soapy water.

- Cleaning the Outer Housing
- Wipe the outer housing with a soft, damp cloth and then polish with a soft, dry cloth.

NOTE

Do not use any abrasive cleaners, pads or cloths which can scratch the surfaces of the machine.

NOTE

Do not clean any of the parts or accessories in the dishwasher.



WARNING

Do not immerse the power cord, power plug or machine in water or any other liquid.

STORING YOUR MACHINE

Before storing, turn the machine off, switch off and remove the power plug from the power outlet. Empty the water tank and drip tray and ensure the machine is cool, clean and dry. Store in an upright position.

Do not place anything on top of machine.

RESET FACTORY ESPRESSO VOLUME SETTINGS

1. Turn the machine off, by pressing the 1 CUP and STEAM buttons simultaneously for 5 seconds.
2. Press and hold the 1 CUP and 2 CUP buttons for 5 seconds. Buttons will illuminate.
3. Press the 1 CUP or 2 CUP buttons and the light will flash 3 times to indicate that all volumes have been reset.
4. Machine will then return to ready mode.

NOTE

Press any other button to exit factory reset mode.

TROUBLESHOOTING

PROBLEM	POSSIBLE CAUSES	EASY SOLUTION
Water does not flow from the group head.	• Water tank is empty.	Fill tank.
	• Water tank is not fully inserted and locked into position.	Push water tank down completely to lock into place.
No hot water.	• Machine needs to be descaled.	Perform descale cycle.
	• Coffee is ground too finely and/or too much coffee in filter basket and/or over tamping and/or filter basket is blocked.	See below, 'Espresso only drips from the portafilter spouts or not at all'.
	• Coffee is ground too finely.	Use slightly coarser grind. Refer to 'Coffee Dose and Tamping' on page 9 and 'Extraction Tips' on page 13.
Espresso only drips from the portafilter spouts or not at all.	• Too much coffee in the filter basket.	Lower dose of coffee. After tamping, trim the coffee dose using the Razor™ dose trimming tool. Refer to 'Coffee Dose and Tamping' on page 9 and 'Extraction Tips' on page 13.
	• Coffee tamped too firmly.	Tamp between or 15–20kg of pressure.
	• Water tank is empty.	Fill tank.
	• Water tank is not fully inserted and locked into position.	Push water tank down completely to lock into place.
	• The filter basket may be blocked.	Use the pin on the end of the provided cleaning tool to unblock the hole(s).
	• Machine needs to be descaled.	Perform descale cycle.
	• Water tank is empty or water level is below MIN.	Fill tank.
Water doesn't come through (the machine makes loud noise).		

TROUBLESHOOTING

PROBLEM	POSSIBLE CAUSES	EASY SOLUTION
Espresso runs out too quickly.	<ul style="list-style-type: none"> Coffee is ground too coarsely. 	Use slightly finer grind. Refer to 'Coffee Dose and Tamping' on page 9 and 'Extraction Tips' on page 13.
	<ul style="list-style-type: none"> Not enough coffee in the filter basket. 	Increase dose of coffee. Tamp then use the Razor™ dose trimming tool to trim off excess coffee. Refer to 'Coffee Dose and Tamping' on page 9 and 'Extraction Tips' on page 13.
	<ul style="list-style-type: none"> Coffee tamped too lightly. 	Tamp between 15–20kg of pressure.
Espresso runs out around the edge of the portafilter.	<ul style="list-style-type: none"> Portafilter not inserted in the group head correctly. 	Ensure portafilter is completely inserted and rotated until resistance is felt.
	<ul style="list-style-type: none"> There are coffee grounds around the filter basket rim. 	Clean excess coffee from the rim of the filter basket to ensure a proper seal in group head.
	<ul style="list-style-type: none"> Too much coffee in the filter basket. 	Lower dose of coffee. Refer to 'Coffee Dose and Tamping', page 9. After tamping, trim the coffee dose using the Razor™ dose trimming tool.
No steam.	<ul style="list-style-type: none"> Machine has not reached operating temperature. 	Allow time for the machine to reach operating temperature.
	<ul style="list-style-type: none"> Water tank is empty. 	Fill tank.
	<ul style="list-style-type: none"> Water tank is not fully inserted and locked into position. 	Push water tank down completely to lock into place.
	<ul style="list-style-type: none"> Machine needs to be decalcified. 	Perform descale cycle.
	<ul style="list-style-type: none"> Steam wand is blocked. 	Refer to 'Cleaning the Steam Wand', page 15.
Pulsing/pumping sound while extracting espresso or steaming milk.	<ul style="list-style-type: none"> The machine is carrying out the normal operation of the pump. 	No action required as this is the normal operation of the machine.
	<ul style="list-style-type: none"> Water tank is empty. 	Fill tank.
	<ul style="list-style-type: none"> Water tank is not fully inserted and locked into position. 	Push water tank down completely to lock into place.

TROUBLESHOOTING

PROBLEM	POSSIBLE CAUSES	EASY SOLUTION
Coffee not hot enough.	<ul style="list-style-type: none"> Portafilter not pre-heated. 	Rinse portafilter under hot water outlet. Dry thoroughly.
Milk too hot.	<ul style="list-style-type: none"> Jug incorrectly positioned. 	Ensure milk jug is correctly positioned on sensor. Adjust milk temperature setting.
No crema.	<ul style="list-style-type: none"> Coffee tamped too lightly. 	Tamp between 15–20kg of pressure.
	<ul style="list-style-type: none"> Coffee is ground too coarsely. 	Use slightly finer grind. Refer to 'Coffee Dose and Tamping' on page 9 and 'Extraction Tips' on page 13.
	<ul style="list-style-type: none"> Coffee beans or pre-ground coffee are not fresh. 	If grinding fresh whole coffee beans, use freshly roasted coffee beans with a 'Roasted On' date and consume between 5–20 days after that date. If using pre-ground coffee, use within a week of grinding.
	<ul style="list-style-type: none"> The filter basket may be blocked. 	Use the pin on the end of the provided cleaning tool to unblock the hole(s).
Water leaking.	<ul style="list-style-type: none"> Auto purge feature. Immediately after the steam function, the machine will purge water into the drip tray. This ensures the thermocoil is at the optimal temperature. 	Ensure the drip tray is firmly pushed in place and emptied whenever the indicator is displayed.
	<ul style="list-style-type: none"> Water tank is not fully inserted and locked into position. 	Push water tank down completely to lock into place.
Machine is on but ceases to operate.	<ul style="list-style-type: none"> The safety thermal-cut out may have activated due to the pump overheating. 	Press the 1 CUP and STEAM button simultaneously for 5 seconds to switch the machine off and unplug from the power outlet. Allow to cool for about 30–60 minutes. If problem persists, call Sage Support.
Too much/too little espresso is being delivered to the cup.	<ul style="list-style-type: none"> Grind amount and/or grind size settings and/or shot volumes require adjustment. 	Adjust the grind amount and/or grind size settings. Refer to 'Coffee Dose and Tamping', page 9 and 'Extraction Tips', page 13.